

In-Line
Membrane/Vacuum
DEGASSER[®]
for High Performance Liquid Chromatography

Model ERC-3215 *α*

Model ERC-3315 *α*

Model ERC-3415 *α*

Operating Manual

Publication No. 77-3015-14

CONTENTS

Warranty	1
Safety Information	1
Safety Symbols	2
1. Introduction	3
2. Principle of Degassing	3
3. Specification	4
4. Unpacking	4
5. Installation	
5-1 Installation	5
5-2 Other Environment	5
5-3 Priming the flow path	5-6
5-4 Hooking up with a solvent delivery pump	6
5-5 Solvent Exchange	6
5-6 Power	6
5-7 Shutdown	6
5-8 Storage	7
6. Front and Rear View of Degasser	7
7. Display and Functional Switches	8-9
8. Getting Started	
8-1 Degasser	9
8-2 Solvent Delivery Pump	9
9. Replacing a Fuse	10
10. Troubleshooting	
10-1 Power	11
10-2 An air bubble is generated at the outlet of Degasser	11
10-3 The solvent isn't passing through	12
10-4 Vacuum pump doesn't stop	12
10-5 Vacuum pump does not run	12

Warranty

ERC Inc.(ERC) warrants its products against defects in materials and workmanship for the period of twelve (12) months from the date of shipment out of its factory.
ERC will, at its option, repair or replace products, which are proved to be defective.

The aforementioned warranty policy shall not be applied to defects being caused by;

- 1 Improper or inadequate maintenance, adjustment, calibration or operation by the user(s);
- 2 User-supplied software, hardware, interfacing or consumable;
- 3 Operation outside of the environmental and electrical specifications for the product;
- 4 Improper site preparation and maintenance; or
- 5 User induced contamination or leaks.

Safety Information

The following general safety precautions must be observed during all course of operation, service, and repair of this instrument. Failure to comply with these precautions or with specific warnings elsewhere in this Operating Manual violates safety standards of design, manufacture, and intended use of degasser.

ERC assumes no liability for the customer's failure to comply with these requirements.
Before installing degasser, please go through Installation section of this Operating Manual.

Do not remove top cover under any circumstance with the power cord is connected. In case of trouble, do not attempt internal service or adjustment. Skilled personnel who are aware of the hazard involved should carry out any service. Unless it is inevitable, please contact our local representative in your area or directly contact ERC for the necessary arrangement.

ERC Inc.
Customer Support Desk
5-8-6 Nishiaoki, Kawaguchi, Saitama 332-0035 Japan
Phone: Japan (81) 48-240-5750 Facsimile: Japan (81) 259-0715

Before degasser is powered on, all protective grounding terminals, extension cords, transformers, and devices connected to a protective grounding via grounding terminal. Any interruption of the protective grounding will cause a potential shock hazard that could result in serious personal injury.

Make sure that only fuses with the required rated current and the specified type are used for replacement. The use of repaired fuses and the short-circuit of fuse holders must be avoided.

Before operating degasser, please go through this Operating Manual thoroughly and keep it always while you operate degasser.

Make sure not using degasser for a purpose other than solvent degassing.

Some solvent like strong acids or low boiling temperature solvent such as fluorinated solvents including but not limited to HFIP may destroy degasser functional components.

In case you plan to use those solvents, please consult us before you start.

Safety Symbols

Below listed Safety Symbols are marked on this instrument or are used throughout the documentation shall represent following:

Warning 	The "warning sign" indicates a potential hazard. It calls attention to a procedure, practice or the like, which, if not correctly done or adhered to, could result in injury or loss of life. Do not proceed beyond a "warranty sign" until the indicated conditions are fully understood and met.
---	---

Caution 	The "caution sign" indicates a potential hazard. It calls attention to an operating procedure, practice or the like, which, if not properly done, could result in damage to or destruction of part or all of the equipment. Do not proceed beyond a "caution sign" until the indicated conditions are fully understood and met.
---	--



SEE MANUAL

The apparatus is marked with this symbol when the user should refer to the Operating Manual in order to protect the apparatus against damage.



This symbol indicates dangerous voltages.



This symbol indicates a protected ground terminal.

1. Introduction

DEGASSER® ERC-3215 α , ERC-3315 α and ERC-3415 α are designed to remove air bubbles or gasses dissolved in a fluid.

When inadequately or not-at-all degassed fluid is pumped into High Performance Liquid Chromatography System (HPLC) or other analytical instruments, air bubbles or dissolved gasses in a fluid could cause many different problems and may interfere a result of analysis at last.

Traditionally, degassing was performed by an ultrasonic technique, a heating technique, Helium sparging technique or vacuum technique in batch mode as a part of preparation for an analysis. Among these traditional degassing techniques, only Helium sparging technique could be used in continuous mode (but only to the certain extent because Helium is supplied by a pressurized container). These techniques, if properly exercised, are effective to make a degassing, however, are not quite effective to guarantee a reproducible and consistent result due to many variances involved in the system such as an individual skill level, a gradually changing Helium pressure, a re-introduction of air after degassing and etc.

ERC introduced a new concept of degassing "In-line DEGASSER®" that is based on a very sophisticated liquid/gas separating membrane technology back in the late 70's and made a truly continuous solvent degassing possible.

This manual covers following three (3) "15 α series" degasser collectively.

ERC-3215 α : two (2) channels

ERC-3315 α : three (3) channels

ERC-3415 α : four (4) channels

2. Principle of Degassing

- (1) Pressure Sensor
- (2) Control Board
- (3) Separating Membrane
- (4) Vacuum Chamber
- (5) 3-way Solenoid Valve
- (6) Vacuum pump
- (7) Solvent delivery pump
- (8) Solvent

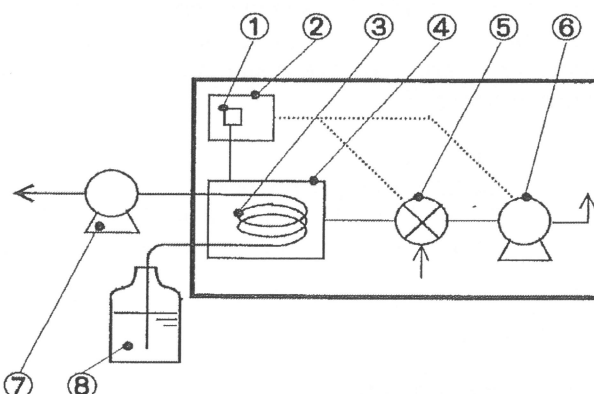

The solvent delivery pump draws solvent through a vacuum chamber (namely through the liquid/gas separating membrane maintained under the vacuum). The vacuum is a mean force to transport dissolved gasses out of solvent. Since the molecule size of dissolved gasses is smaller and holds a higher mobility than the one of solvents. Also, its higher compatibility let gasses permeate the membrane and emigrate out of solvents. Depending upon application, the vacuum pump could be operated on either continuous mode (CONT.) or intermittent mode (NORM: normal or standard mode).

3. Specification

(1) Degassing Efficiency	Air bubbles shall not be observed at the outlet of degasser when de-ionized water is pumped through at flow rate 3ml/min., at 25 degree Celsius ambient temperature. Reference: DO (dissolved oxygen) is 2 ppm at 3ml/min.
(2) Internal volume	Approximately 7 ml per channel.
(3) Pressure Rating	Maximum 198 kPa (2 kgf/cm ²)
(4) Numbers of Solvent	2 solvents (channels): ERC-3215 α 3 solvents (channels): ERC-3315 α 4 solvents (channels): ERC-3415 α
(5) Wetted Material	PEEK (Inlet/Outlet port) PTFE (Separating Membrane and Tubing)
(6) Dimension	71mm (W), 135mm (H), 310mm (D)
(7) Weight	ERC-3215 α: approx. 5.1kgs ERC-3315 α: approx. 5.4kgs ERC-3415 α: approx. 5.5kgs
(8) Power Requirement	AC 100 - 240V (50/60HZ)
(9) Anti-Bedewing Procedure	At each time when the vacuum pump is either started or stopped, the solenoid valve switches to suction outside air to dry diaphragm of vacuum pump and vacuum line.

4. Unpacking

As you are unpacking the shipping carton, please double check whether following standard accessories are enclosed together with Degasser. If there is any item(s) missing in the carton, please notify that our local representative in your area or ERC at following address.

ERC Inc.
Customer Support Desk
5-8-6 Nishiaoki, Kawaguchi, Saitama 332-0035 Japan
Phone: Japan (81) 48-240-5750 Facsimile: Japan (81) 259-0715

(Standard Accessories)

P/N 7730101	Operating Manual	
P/N 8828080	Inlet Tube (PTFE: 3x2x1000mm L: with fittings & ferrules)	1 - 4 sets
P/N 8828090	Flangeless fittings and ferrules	1 - 4 sets
P/N 9306070	Syringe	1 ea
P/N 8828100	Connecting joint for a syringe	1 ea
P/N 2400850	Fuse (T500mA/250V)	2 ea
P/N 4300120	Power cord	1 ea
	(Use for 100V only. Use an appropriate Power cable when Power is supplied other than 100V)	

5. Installation

5-1. Installation

	Warning Keep this instrument away from the flame. Choosing a place where a sufficient ventilation is available. Make a proper grounding to prevent an electrical shock and to maintain a stable operation of instrument.
---	---

To install degasser, make sure choosing a flat and stable basis. As harmful solvent may be used for HPLC analysis, make sure choosing a place where sufficient ventilation is available. In case using a flammable solvent, do not operate this instrument in the presence of flammable gasses or fumes.

Degasser is equipped with a motor and may generate a slight vibration. So, it should be avoided to put anything on top of it.

5-2 Other Environment

The ambient temperature should be within a range of 10 - 40 degree Celsius and the humidity should be within 40 - 85%.

5-3. Priming the flow path

(Note) An entire flow path of degasser is dried out before the shipment. Before hooking up with the solvent delivery pump, the flow path of degasser should be manually primed with the solvent since the solvent delivery pump may not draw the solvent.

- (1) Put the end of tubing, which is connected with the inlet port of degasser, into the solvent reservoir.
When using an inlet filter, be sure not using the one clogged or the one with too small mesh size filter.
- (2) Connect the syringe/connecting joint to the outlet port and gradually draw the solvent to prime the flow path. Be sure not drawing the solvent fast (quick suction generate an air bubble within the flow path due to the vacuum effect).

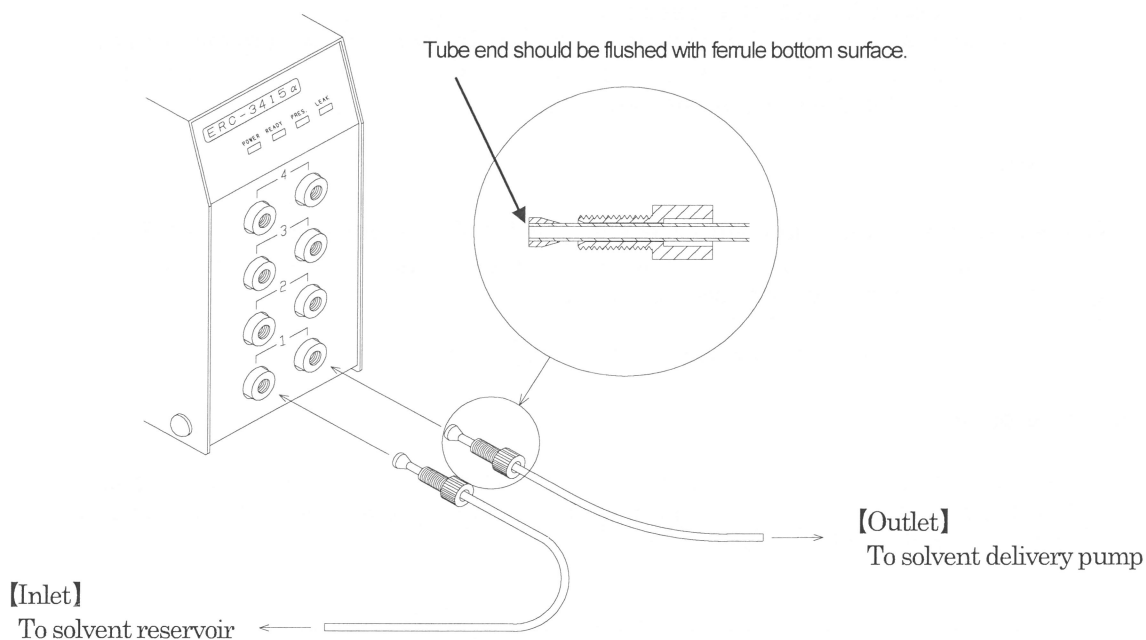

- (3) It is not necessary to fill the entire internal volume of flow path with the solvent. As you see the solvent flows into a syringe, you have primed the flow path adequately. If you keep the position of reservoir slightly higher than degasser, you may make this process easier.

5-4. Hooking up with a solvent delivery pump

Detach a syringe/connecting joint from the outlet port and connect the outlet port of degasser with the suction-side (or inlet side) of solvent delivery pump or mixing joint installed in prior to the pump as you confirm the solvent drips from the outlet port. To prevent generating a high backpressure, use 3mm OD, 2mm ID PTFE tubing. These inlet/outlet ports are not marked as "IN" or "OUT" and they are not really specified that way. The connection with inlet/outlet ports could be reversed as long as these two (2) ports are next to each other in parallel position (not in vertical position).

- (Note) The length of tubing between degasser and solvent delivery pump should be minimized to prevent a restrictive flow resistance affecting the performance of solvent delivery pump and to minimize a potential re-introduction of air into the degassed solvent.

5-5. Solvent Exchange

- (1) If degasser is not connected with solvent delivery pump:

Wash the flow path and filled with a solvent planned to be used by the syringe/connecting joint.

- (2) If Degasser is connected with solvent delivery pump:

Refer to the operating manual of solvent delivery pump and follow to the instruction given in it.

- In case of changing a solvent which has a different polarity from the new solvent, it maybe better to switch over to the other solvent which has a compatibility to both solvents.
- In case of switching between a buffer solution and an organic solvent, make sure pumping de-ionized water in between. They may precipitate a salt within the flow path as they meet.

5-6. Power

Connect a power cord(standard accessory) to the line-power socket("~LINE") on the rear panel. It is recommended to use a three-contact power source with the ground contacts securely connected to ground.

Power requirement: AC 100 - 240 V 50/60 Hz

5-7. Shutdown

The degasser has neither "Start" nor "Stop" switches. The vacuum pump starts when the unit is powered on. You may shutdown degasser even while a vacuum pump running by turning off degasser.

5-8. Storage

- (1) After the solvent delivery pump is stopped, you may keep degasser powered on if you use your system regularly.
- (2) For a long-term shutdown, you are recommended to wash the flow path with the de-ionized water adequately to prevent a salt precipitation, microorganism, and algae especially in case of a buffer solution.
- (3) After washing with de-ionized water, pump methanol and dry out the flow path.
- (4) Sealing every inlet/outlet ports off with a sealing cap or plug is recommended.
- (5) The temperature of storing place should be within a range of 0 - 60 degree Celsius.

6. Front and Rear View of Degasser

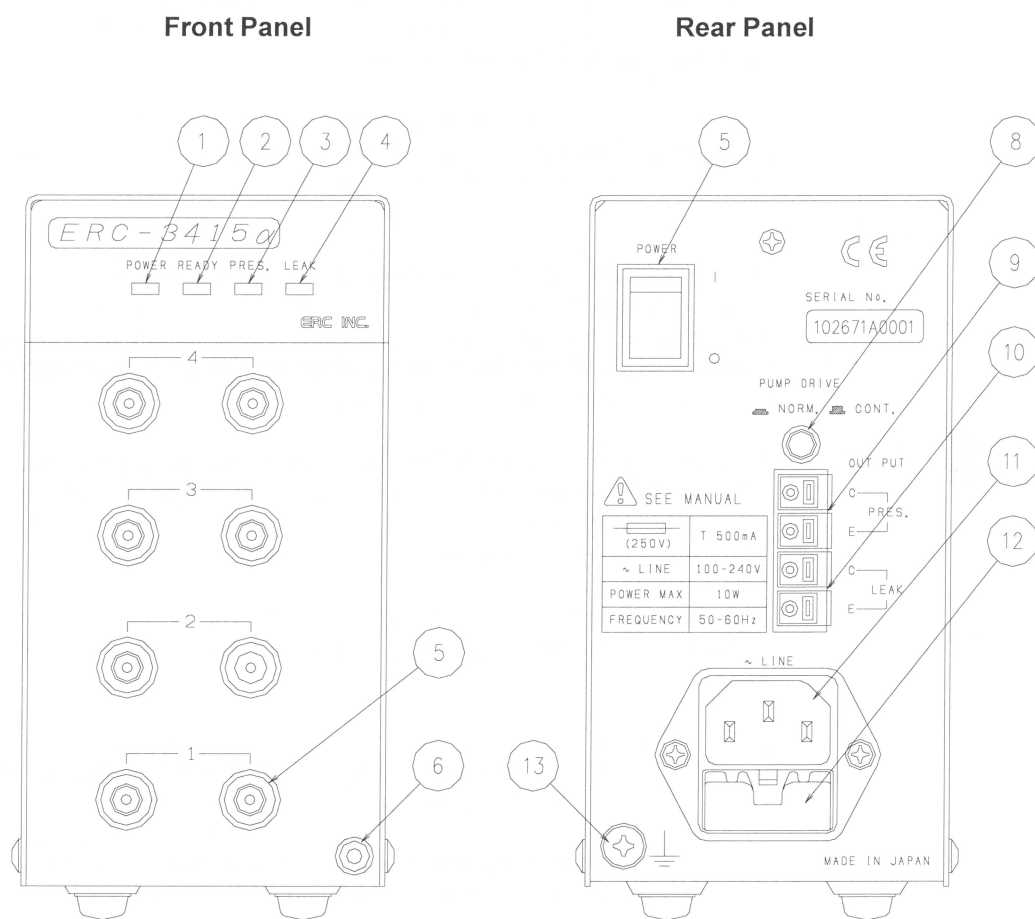

(Note) The above figure is ERC-3415 α . The other model has a difference only in number of channel.

- | | |
|--|--------------------------------|
| (1) POWER | (8) Pump-Driving Mode Switch |
| (2) READY | (9) Signal Out: Pressure Error |
| (3) PRES. | (10) Signal Out: Leak Error |
| (4) LEAK | (11) LINE power socket |
| (5) Inlet / Outlet Ports (1/4" - 28 UNF: Female) | (12) Fuse Holder |
| (6) Drain Port | (13) Ground Terminal |
| (7) POWER switch | |

7. Displays and Functional Switches

- (1) POWER This Green LED shall be illuminate when degasser is powered on
- (2) READY This Green LED shall be illuminated when the status of degasser. When the vacuum level of vacuum chamber is maintained to be lower than the designated pressure level, this LED indicates the readiness of degasser for operation by being illuminated.
- (3) PRES. This Red LED illuminates when the pressure level of vacuum chamber exceeded and did not return to the designated pressure level in a defined length of time after a vacuum pump restarted..
- (4) LEAK This Red LED shall be illuminated when the built-in leak sensor finds a leak. If this LED is illuminated during the operation, stop your solvent delivery pump, turn off the power degasser, disconnect the power cord of degasser and call for a service. If the solvent employed is either flammable or harmful, make sure having adequate ventilation available.
- (5) PUMP DRIVE This push switch shall be used to select a driving mode of vacuum pump of the Degasser. As marked, a position of switch indicates currently selected pump-driving mode.

■ NORM.

This intermittent mode is a standard pump-driving mode. Under this mode, the vacuum pump will be restarted whenever the pressure level of vacuum chamber exceeds the designated pressure level and will be stopped when the pressure level comes back into the designated pressure range.

■ CONT.

The continuous mode is to drive the vacuum pump continuously. If the purpose of degassing is to remove the dissolved gasses in solvent (in another word, the analysis is very sensitive to these dissolved gasses), this mode is recommended.

The continuous mode will shorten the service life of vacuum pump. Unless it is needed, we recommend choosing an intermittent mode.

(TIPs) When “PRES.” LED illuminates, you may choose this mode at once to check whether the vacuum pump is functioning or not. If the vacuum pump is functioning, you may extinguish the “PRES.” LED by continuous pumping. If that is the case, the unit may have a minor air leak with the vacuum chamber or somewhere in the vacuum line.

External Signal Out	Degasser generates following two different output signals.
Pressure	As "PRES." LED illuminates, this open collector signal is generated to indicate a pressure error has occurred PRESSURE C: Pressure Error: Collector Side PRESSURE E: Pressure Error: Emitter Side (35V, 50mA Maximum)
Leak	As "LEAK" LED illuminates, this open collector signal is generated to indicate that a leak is detected. LEAK C: Leak Error: Collector Side LEAK E: Leak Error: Emitter Side (35V, 50mA Maximum)

8. Getting Started

8-1. Degasser

- (1) Power on degasser
- (2) Wait for the "READY" LED illuminates
- (3) Ready for pumping solvent

(Note) As the vacuum pump restarts, the "READY" LED may be extinguished at once. You may disregard this since it has nothing to do with degasser performance.

8-2. Solvent Delivery Pump

As you can see the "READY" LED illuminates, you may start pumping of solvent delivery system.

(Note) Maximum flow rate of degasser is 20ml/min. However, this flow rate specification is just for purge purpose of the flow path.

High flow rate may cause a capitation type phenomenon within a flow path. The maximum flow rate, however, is varied depending upon the type of solvent or mixture.

It is recommended, if possible, to keep the flow rate below 3ml/min. to optimize degassing efficiency.

9. Replacing a Fuse

Warning  Make sure that Power Switch is off and the Power Cable is disconnected as you are changing Fuses. Also, make sure to choose an appropriate Fuse according to the specifications stated above.

- (1) Make sure the power cord is disconnected.
- (2) Pull out the Fuse Holder Cap as pushing the Cap Stopper downward a little.
- (3) Pull out Fuses from the Fuse Holder.
- (4) Insert new fuses into the Fuse Holder.
- (5) Insert and push to lock the Fuse Holder Cap.
- (6) Make sure using only fuses with required rated current and specified type for replacement. (T500mA, 250V)

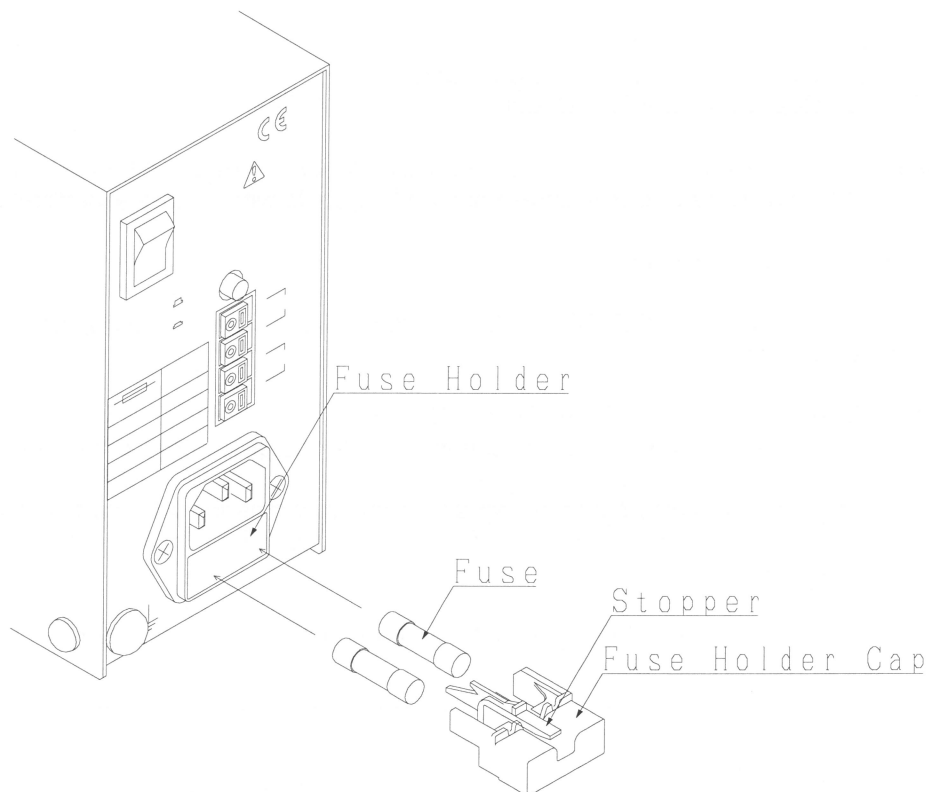

10. Troubleshooting

10-1. Power

POWER LED does not illuminate though the POWER Switch is on.

- Is the power cord connected securely to the LINE power socket?
- Is the power cord connected securely to the wall outlet?
- Aren't fuses brown off (Refer to the above **Section 9**)?
- If fuses are brown off, replace them with the new one.
- If the problem is not disappeared or repeated, contact our local representative in your area or ERC.

10-2. An air bubble is generated at the outlet of degasser.

(1) An air bubble is generated while the flow path is being purged (Sucking a solvent by the syringe).

- Make sure not drawing a plunger of syringe slowly and gently.
- If you still see an air bubble, make sure each connection throughout the flow path is securely made.
Loosely connection causes the suctioning of air into the system.
- Make sure nuts and ferrules are securely fastened.

(2) An air bubbles is appeared as the solvent delivery pump is pumping s solvent.

- Make sure pumping a solvent within the rated flow rate range.
If the flow rate exceeds the rated range, the decreased degassing efficiency and the increased internal flow resistance of tubing could generate an air bubble.

(Note) If the solvent delivery pump is equipped with the "system purge" switch, the flow rate during such purging process may be far greater than the rated flow rate range.

- If a negative pressure incurred within the flow path, an air bubble or a vaporizing-layer could be created. Make sure the solvent filter is not clogged and is clean.

(Note) If the position of solvent reservoir is to low or the length of tubing is too long, the negative pressure could be generated.

- Make sure a solvent exchange is adequate to prevent these solvents meet within the flow path.

(Note) In case of changing a solvent, which has a different polarity from the new solvent, it may be better to switch over to the other solvent which has a compatibility to both solvents at once.

10-3. The solvent isn't passing through.

If the solvent does not come out from the outlet of degasser:

- Make sure no clogging within the flow path including a solvent filter.

(Note) When a solvent is exchanged between a buffer solution and an organic solvent, the salt could be precipitated within the flow path if the washing/exchanging was not properly done.

The internal flow path of degasser must be washed at once before applying the other solvent.

- Make sure not having a negative pressure environment within the flow path.

(Note) If the position of solvent reservoir is too low or the length of tubing is too long, the negative pressure could be generated.

10-4. Vacuum pump doesn't stop.

- Make sure the continuous mode is not selected with the Pump-Drive Mode Switch.
- Select the intermittent mode (NORM) with the Pump-Drive Mode Switch.

If the vacuum pump is still running:

- Possible to have following problems: Contact our local representatives in your area or ERC.

Loosely connection within the vacuum line (vacuum tubing, joint so force)

Valve (diaphragm) malfunctioning

Defective pressure sensor

10-5. Vacuum pump does not run.

(1) If POWER LED is extinguished:

- Aren't fuses brown off (Refer to the above **Section 9**)?
- If fuses are brown off, replace them with the new one.

(2) If PRES. LED illuminates:

- Turn off the power and turn on the power to check if PRES. LED could be extinguished.

If PRES. LED illuminates again and the vacuum pump stops:

- Seems to have a failure within the vacuum line such as broken vacuum tubing.

Contact our local representative or ERC.

(3) Vacuum pump stopped all of sudden.

- Possible failure with the pressure sensor.

Contact our local representative or ERC.